

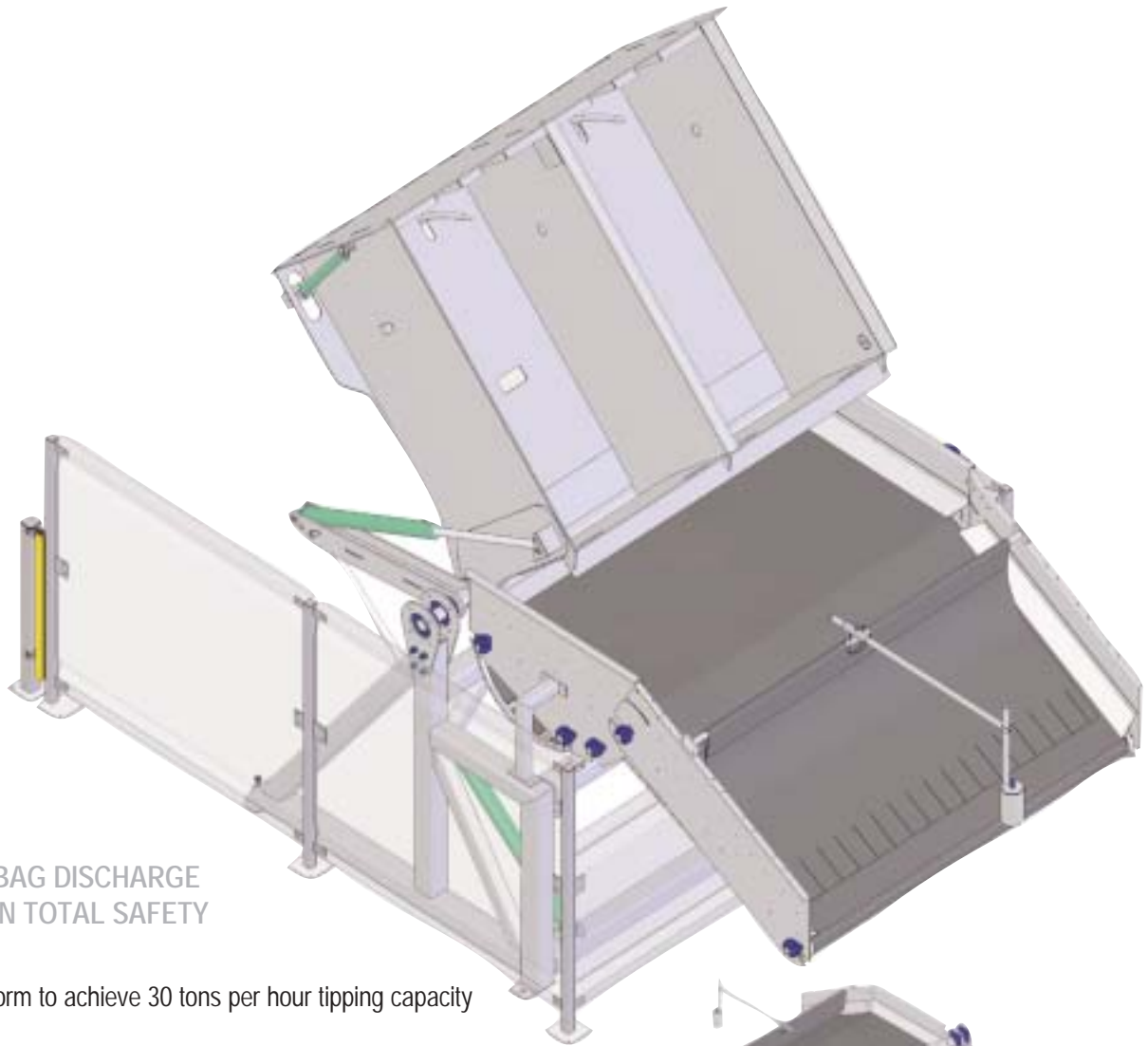

NEW TWIN BIG BAG TIPPER

Simple but effective tipping of big bagged produce



BAG DISCHARGE
IN TOTAL SAFETY

FEATURES

- Twin tipping platform to achieve 30 tons per hour tipping capacity
- Bag in sensors
- Hydraulic clamp for bags
- Two stage tipping process
- Controlled discharge of product under probe control
- Manually adjustable door
- Manual start sequence
- Manual removal of empty bag
- Hydraulic power pack
- Control panel to sequence tipping cycle
- Category 4 light beam safety system
- Heavy duty system

2.4m long x 2400mm wide In line Delivery Belt

- Electronic variable speed drive
- High sides to retain crop
- Product PC cell to control tipper
- Probe sensor to control feed into hopper
- Mounted to back of tipper

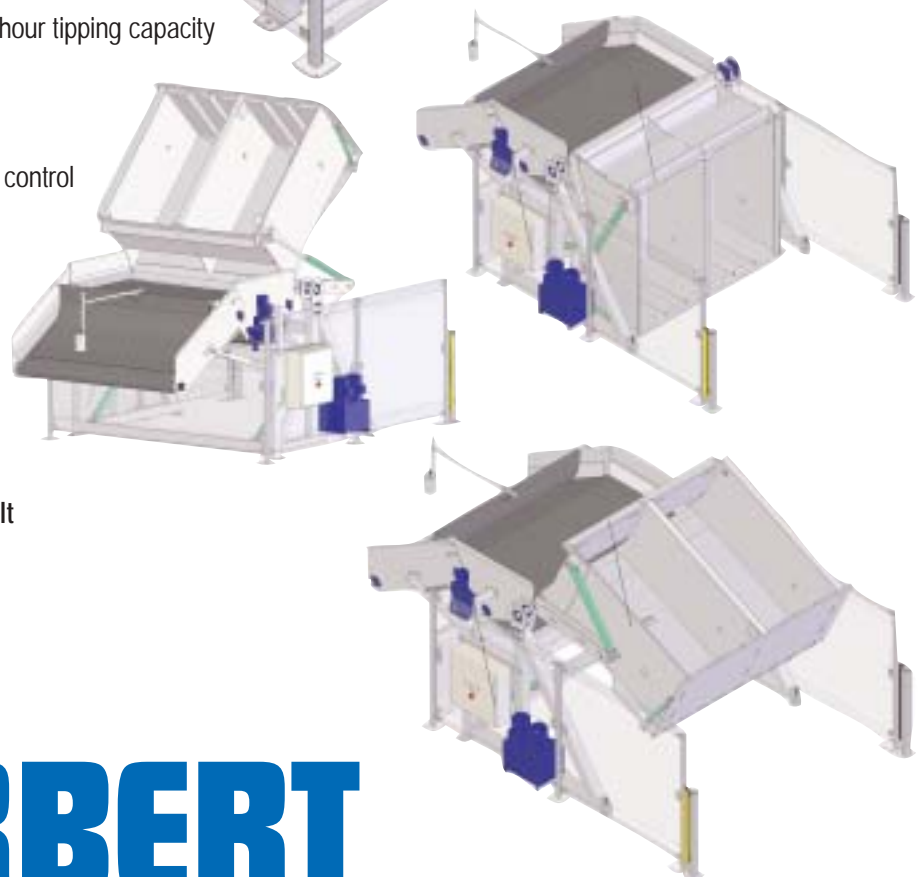

HERBERT

T: +44(0)1945 430666 F: +44(0)1945 430487 E: sales@rjherbert.co.uk W: www.rjherbert.co.uk