

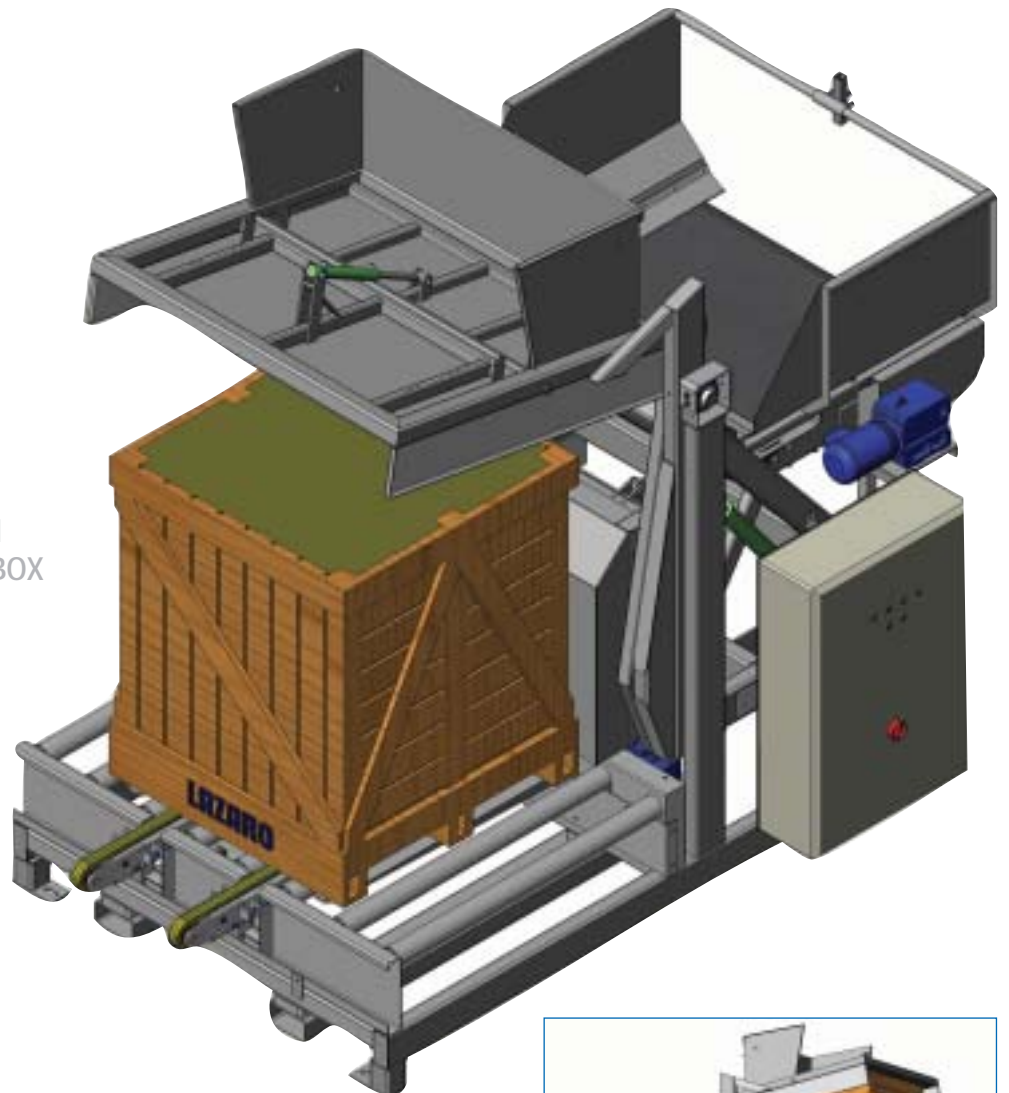

FTTS

HIGH ANGLE BOX TIPPER WITH AUTO-BOX DISCHARGE

HIGH ANGLE
TIPPING WITH
AUTOMATIC BOX
INFEED AND
OUTFEED



FEATURES

- 145° rotation to give positive emptying of boxes
- Uprated hydraulic system giving up to 30 tip cycles per hour
- Gentle controlled flow emptying
- Fully automated tipping sequence
- Empty box ejected sideways onto awaiting platform
- 0.75 tonne holding hopper/conveyor with auto-variable flow rate to ensure smooth delivery of crop
- Reduction in box handling prevents premature wear on boxes
- Cross matrix light curtain safety system
- Standard unit capable of handling up to 1.1m high boxes
- Space saving design (ejection of empty box in same vertical plane as full)

OPTIONS

- Specialist models available on request (i.e. 2 tonne boxes)
- Increased capacity holding hoppers
- Split door facility for part emptying boxes



HERBERT